

**Submersible Dewatering Vortex Pump
For Low Water Level**

LSR2.4S Model

OPERATION & SERVICE MANUAL



TSURUMI MANUFACTURING CO., LTD.

INTRODUCTION

Thank you for selecting the LSR2.4S model Tsurumi Submersible Dewatering Vortex Pump For Low Water Level application.

This manual explains how to use this equipment and gives instructions on precautions to take during use. In order to understand the features of the LSR2.4S model and to use it in the most effective manner, be sure to read this manual and understand its contents before using the pump.

This equipment should not be used for applications other than those listed in this manual. Failure to observe this precaution may lead to a malfunction or an accident. In the event of a malfunction or an accident, the manufacturer will not assume any liability. After reading this Operation Manual, keep it in a location that is easily accessible, so that it can be referred to whenever information is needed while operating the LSR2.4S model.

In case this equipment is lent to another party, be sure to also lend this Operation Manual together with the equipment.

If this Operation Manual becomes lost or damaged, contact the dealer where this equipment was purchased, or the Tsurumi sales office in your area.

This manual was prepared with the utmost attention to detail. However, if any errors or omissions are encountered, contact the dealer from whom this unit was purchased, or the Tsurumi sales office in your area.

The content of this manual may not be copied, in whole or part, without consent of Tsurumi Manufacturing Co., Ltd.

CONTENTS

[1] PUMP PART NAMES	2	[6] MAINTENANCE AND INSPECTION	9
[2] PRIOR TO USE	2	Prior to Inspection	9
Inspecting the Product	2	Daily and Periodic Inspection	9
Inspecting the Specification	2	Storage	10
Product Specification	2	Oil Inspection and	
[3] INSTALLATION	3	Changing Procedures	10
Preparation for Installation	3	Maintenance	10
Pre-Installation Check	3	[7] DISASSEMBLY AND REASSEMBLY	
Precautions During Installation	4	PROCEDURE	11
[4] ELECTRICAL WIRING	5	Disassembly Procedure	11
Electrical Wiring Work	5	Disassembly Diagram	11
Grounding	5	Reassembly Procedure	12
Connecting the Power Supply	5	[8] TROUBLESHOOTING	13
Cabtyre Cable	6		
Connecting the Cabtyre Cable	6		
Wiring Diagram	6		
[5] OPERATION	7		
Prior to Operation	7		
Trial Operation	7		
Operation	8		
Operating Water Level	8		

1

PUMP PART NAMES

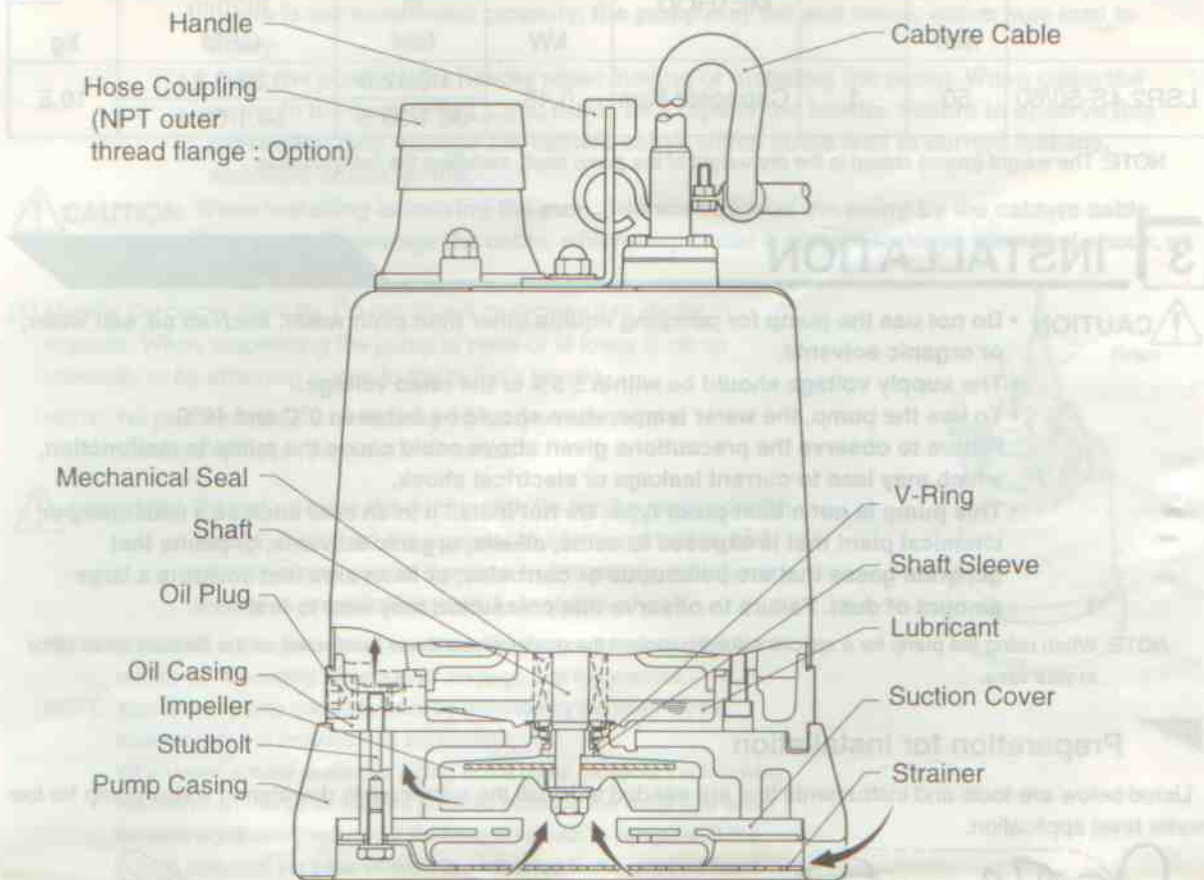

2

PRIOR TO USE

Check the following points after receiving the pump:

Inspecting the Product

Unpack and verify that no damage has occurred to the pump during shipment and that the bolts and nuts have not loosened.

Inspecting the Specification

Check the nameplate of the pump unit to verify what you have ordered. Pay particular attention to its voltage and frequency specifications.

NOTE: If you discover any damage or discrepancy, please contact the dealer where this equipment was purchased, or the Tsurumi sales office in your area.

Product Specification

CAUTION Never use the product under conditions other than those that are specified in the product specification, as they may lead to current leakage, electrical shock, fire, or water leakage.

Main Components Specifications

LIQUID	TYPE / TEMPERATURE	Spring water, work drainage, and muddy water / (MAX.) 40°C
PUMP	IMPELLER	Vortex-Type
	SHAFT SEALING	Double mechanical seal
	BEARING	Shielded ball bearing
MOTOR	SPECIFICATION	Dry type submersible induction motor, 2 poles
	INSULATION	Class E or B (Option)
	PROTECTOR (built-in)	Miniature protector
	LUBRICANT	Turbine oil VG32
CONNECTION		Hose coupling (NPT outer thread flange : Option)

■ Standard Specifications Common to 50/60Hz

MODEL	BORE mm	PHASE	STARTING METHOD	OUT-PUT kW	MAX.HEAD		MAX.CAPACITY m ³ /min GPM	WHT kg
					m feet			
LSR2.4S-50/60	50	1	Capacitor-Run	0.48	11.0/12.0		0.22/0.24	10.5
					36.1/39.5		58.1/62.4	

NOTE: The weight (mass) shown is the dry weight of the pump itself, excluding the cabtyre cable.

3 INSTALLATION

- CAUTION**
- Do not use the pump for pumping liquids other than plain water, such as oil, salt water, or organic solvents.
 - The supply voltage should be within $\pm 5\%$ of the rated voltage.
 - To use the pump, the water temperature should be between 0°C and 40°C.
- Failure to observe the precautions given above could cause the pump to malfunction, which may lead to current leakage or electrical shock.
- This pump is not a dust-proof type. Do not install it in an area such as a machinery or chemical plant that is exposed to acids, alkalis, organic solvents, or paints that generate gases that are poisonous or corrosive, or in an area that contains a large amount of dust. Failure to observe this precaution may lead to fire.

NOTE: When using the pump for a special solution, contact the dealer where it was purchased, or the Tsurumi sales office in your area.

Preparation for Installation

Listed below are tools and instruments that are needed to install the submersible dewatering vortex pump for low water level application.

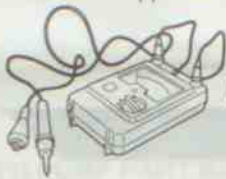

Insulation resistance tester (megger)



AC voltmeter (tester)



AC ammeter (clamp tester)



Tools for fastening bolts and nuts



Tools for connecting the power supply (a screwdriver or a box wrench)

NOTE: Consult the operation manual provided with each tester for the proper use of the tester.

Pre-Installation Check

Using a megger, measure the resistance between each terminal of the plug of the cabtyre cable and the ground terminal to verify the insulation resistance of the motor.

■ Insulation resistance reference value = 20MΩ or greater

NOTE: The insulation resistance reference value of 20MΩ or greater, is based on a new or repaired pump. For reference values of a pump that has already been put into operation, refer to "6. Maintenance and Inspection" on page 9 of this manual.

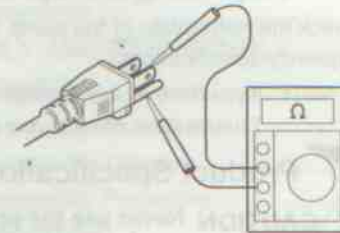

ITEM	DESCRIPTION	REMARKS
1	CONNECTION	
2	LUBRICANT	
3	PROTECTIVE COVER (Dust-Proof)	
4	INSULATION	
5	ADJUSTMENT	
6	OPERATION	
7	BEARING	
8	SHAFT SEALING	
9	IMPELLER	
10	LIQUID TEMPERATURE	

Precautions During Installation

! WARNING • When installing the pump, be mindful of the pump's center of gravity and weight. If the pump is not suspended properly, the pump may fall and break, which may lead to injury.

• Hold the pump by its handle when moving or installing the pump. When using the pump in the suspended state, firmly tie a rope to the handle. Failure to observe this precaution may damage the cable, which could lead to current leakage, electrical shock, or fire.

! CAUTION When installing or moving the pump, do not suspend the pump by the cable. Doing so will damage the cable, which may cause a current leakage, electrical shock, or fire.

- (1) Handle the pump carefully. Do not drop it or expose it to strong impacts. When suspending the pump to raise or to lower it, do so manually or by attaching a rope to the pump's handle.

NOTE: For proper procedures for handling the cable, refer to "4. Electrical Wiring" on page 5 of this manual.

! CAUTION Do not operate the pump with its intake clogged with debris. Doing so may generate abnormal noise and vibration and cause damage to the pump, which may lead to current leakage and electrical shock.

NOTE: For details on the water level necessary for pump operation, refer to the section on "Operating Water Level" on page 8 of this manual.

NOTE: Appropriate piping materials must be provided by the user. Piping materials are not included with the product.

When using a hose to provide piping to the pump, observe the following:

Maintain the hose as straight as possible because the water flow could become significantly reduced if the hose is kinked. In particular, if the hose is kinked at the base where it is connected to the pump, it could create air pockets in the pump, causing the pump to operate dry.

Therefore, unbend the hose while operating the pump. Extend the end of the hose (discharge side) above the water surface. If the end of the hose is submerged in water, it may cause the water to flow back when the pump has been stopped. If the end of the hose is located at a level that is lower than that of the source water surface, water may continue to flow out even after the pump has been stopped.

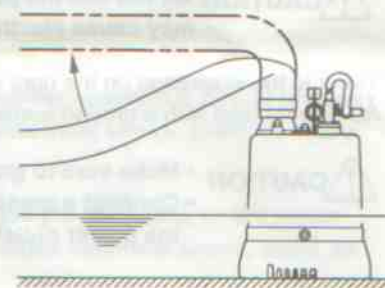
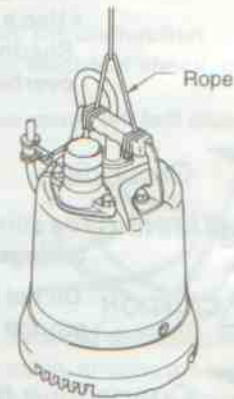

! CAUTION • In order to properly discharge water, provide an adequate hose to the area where the pump is mounted. Failure to do so may lead to water leakage, which could damage the surrounding walls, the floor, or materials.

• If an excessive amount of sediment is drawn into the pump, it may cause the pump to wear, which can lead to current leakage or electrical shock.

- (2) The pump must be placed upright during operation. If there is a risk of the pump drawing in debris or sediment, operate the pump inside a basket or by enclosing it in a net.

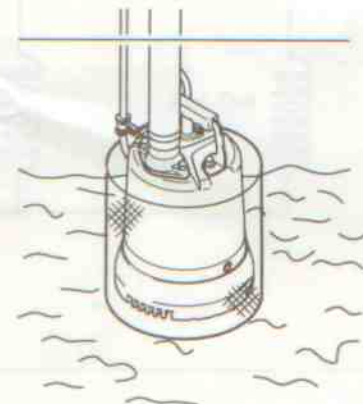

4

ELECTRICAL WIRING

Electrical Wiring Work

WARNING All electrical work should be carried out by an authorized electrician, in compliance with the laws and wiring codes of the respective country in which the work is being performed. Never allow an unauthorized person to perform electrical work because it is not only against the law, but it can also be extremely dangerous.

- Improper wiring can lead to current leakage, electrical shock, or fire.
- Be sure to use a ground leakage breaker and an overcurrent protector to prevent damage to the pump, which may lead to current leakage and electrical shock.
- Use a power outlet that is rated 15A or above, provided exclusively for this unit. Sharing a multiple outlet with other pieces of equipment could cause the outlet to overheat, which could lead to a fire.

Be sure that the power supply and wiring have adequate capacity.

Grounding

WARNING Be sure to install the ground wire securely. Failure to observe this precaution could damage the pump and cause current leakage, which may lead to electrical shock.

CAUTION Do not connect the ground wire to a gas pipe, water pipe, lightning rod, or telephone ground wire. Improper grounding could cause electrical shock.

Connecting the Power Supply

WARNING Before connecting the cabtyre cable, make sure that the power supply (i.e. circuit breaker) is properly disconnected. Failure to do so may lead to electrical shock, short, or injury caused by the unintended starting of the pump.

CAUTION Do not use the pump if the cabtyre cable is damaged. Failure to observe this precaution may cause electrical shock, short, or fire.

Refer to the illustration on the right when using a single-phase AC power outlet with a ground terminal.

CAUTION

- Make sure to ground the ground wire.
- Connect a prescribed circuit breaker to the power outlet.

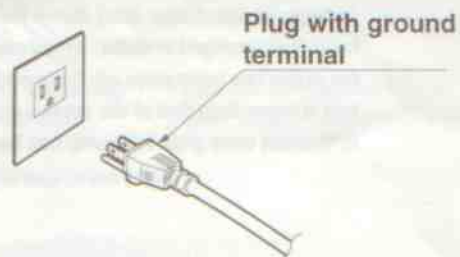

Tighten the terminals at the end of the cabtyre cable securely against the terminal board of the control panel, as illustrated on the right.

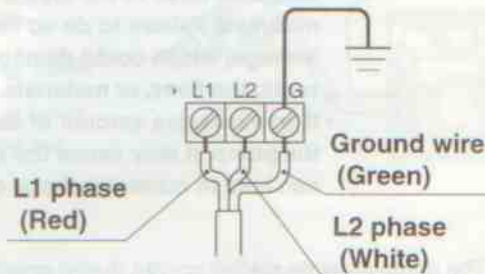

Cabtyre Cable

- CAUTION** • If the cabtyre cable must be extended, use an extension cable with the same or larger core size as that of the cable that is provided with the pump. Failure to use a cable of proper size will prevent the motor from attaining its full potential and may also cause the cable to overheat, which may lead to fire, current leakage, or electrical shock.
- If a cabtyre cable with a cut or damaged sheath is submerged in water, the water may enter the pump motor and cause the motor to short. This will damage the pump, which may lead to current leakage, electrical shock, or fire.
 - To prevent the cable from cuts or twists, which will damage the pump and may lead to current leakage, electrical shock, or fire, be sure that the tires of vehicles do not run over the cabtyre cable.
 - If the cabtyre cable must be submerged in water, be sure to mold the connection portion completely. Failure to do so may lead to current leakage, electrical shock, or fire.



Never submerge the ends of a cabtyre cable in water.

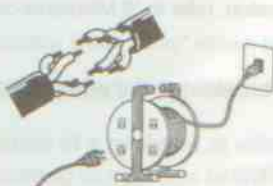

If the cabtyre cable must be extended, use an extension cable with the same or larger core size as that of the cable that is provided with the pump.



To prevent water from entering inside the cable, be sure to securely mold the cable connection portion.



To avoid damaging the cable, arrange the cable run so that the cable is not bent, kinked, or pressed against a structure.

Connecting the Cabtyre Cable

- WARNING** Before connecting the power plug, make sure that the power supply (i.e. circuit breaker) is properly disconnected. Failure to do so may lead to electrical shock, short, or injury caused by the unintended starting of the pump.

- CAUTION** Do not use the pump if the cabtyre cable or the power plug is damaged, or the power outlet is loose. Failure to observe this precaution may cause electrical shock, short, or fire.

Wiring Diagram

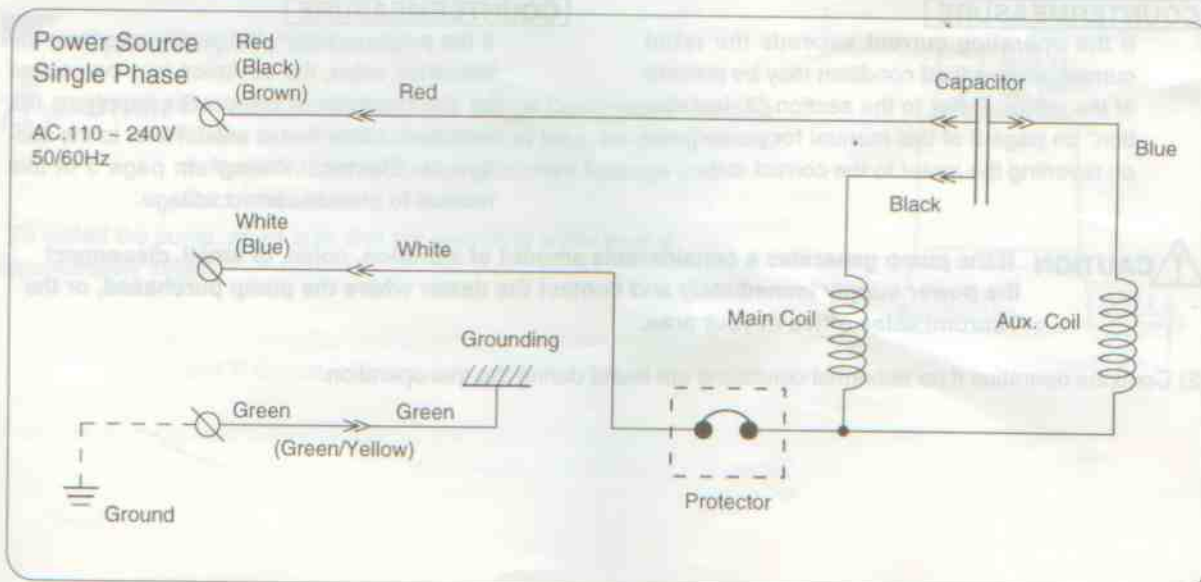

5

OPERATION

Prior to Operation

- (1) Once again, check the nameplate of the pump to verify that its voltage and frequency are correct.

CAUTION Improper voltage and frequency of the power supply will prevent the pump from attaining its full potential, and may also damage the pump.

NOTE: Verify the specs on the pump's nameplate.

- (2) Check the wiring, power supply voltage, the capacity of the ground leakage circuit breaker, and the insulation resistance of the motor.

■ Insulation resistance reference value = $20M\Omega$ or greater.

NOTE: The insulation resistance reference value of $20M\Omega$ or greater is based on a new or repaired pump. For reference values of a pump that has already been put into operation, refer to "6. Maintenance and Inspection" on page 9 of this manual.

- (3) Adjust the setting of the overflow protector (i.e. circuit breaker) to the pump's rated current.

NOTE: Verify the rated current on the pump's nameplate.

Trial Operation

WARNING

- Never start the pump while it is suspended, as the pump may jerk and cause a serious accident involving injury.
- Never start the pump where people are present, as they may suffer electrical shock from current leakage.

- (1) Operate the pump for a short time (3-10 minutes) and verify the particulars given below.

Using an AC ammeter (clamp), measure the current for the operation at the power outlet.

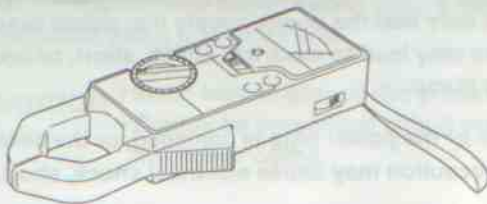

Using an AC voltmeter (tester), measure the voltage at the power outlet.

■ Power supply voltage tolerance = within $\pm 5\%$ of the rated voltage

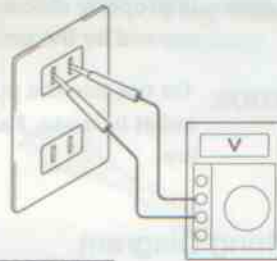

COUNTERMEASURE

If the operating current exceeds the rated current, an overload condition may be present at the motor. Refer to the section "3. Installation" on page 3 of this manual for procedures on reverting the motor to the correct state.

COUNTERMEASURE

If the power supply voltage deviates from the tolerance value, the deviation may be caused by the capacity of the power supply or the extension cable that is used. Refer to the section "4. Electrical Wiring" on page 5 of this manual to provide correct voltage.

CAUTION If the pump generates a considerable amount of vibration, noise, or smell, disconnect the power supply immediately and contact the dealer where the pump purchased, or the Tsurumi sales office in your area.

- (2) Continue operation if no abnormal conditions are found during the trial operation.

Operation

- ! WARNING** • The pump may be extremely hot during operation. To prevent burns, do not touch the pump with bare hands.
- Do not insert foreign matter (metallic objects such as pins or wires) into the suction inlet of the pump. Failure to observe this precaution may lead to malfunction or operate abnormally, which could cause current leakage and electrical shock.
 - When the pump is not used for a long time, make sure to disconnect the power plug from the outlet. If the wiring insulation deteriorates with the power supply connected, it may cause current leakage, electrical shock, or fire.
 - During a power outage, be sure to keep the pump OFF by disconnecting the power supply. Unintentional operation of the pump after power resumption may cause extreme danger to people around the unit.

Pay attention to the water level during the pump operation. The pump will become damaged if it is allowed to operate dry.

NOTE: Refer to the section "Operating Water Level" shown below.

The pump is equipped with a motor protective device.

- ! CAUTION** Unless the cause of a problem is eliminated, the pump will repeat the stop-and-go cycle, eventually resulting in damage to the pump. Therefore, be sure to remove the cause of the problem.

- ! WARNING** During inspection and repair, make sure to disconnect the power supply to prevent the pump from starting unintentionally.

To protect the motor, if a current overload occurs in the motor or if the motor overheats under the conditions given below, the pump will stop automatically, regardless of the water level during operation.

- Extreme fluctuation of power supply voltage
- Pump operated under overload condition
- Pump operated at open phase or binding condition

- ! CAUTION** Operating the pump in this manner will prevent it from attaining its full potential, and may also generate abnormal noise and vibration and cause damage to the pump.

In particular, if the hose is kinked at the base where it is connected to the pump, it could create air pockets in the pump, causing the pump to operate dry. Therefore, unbend the hose while operating the pump.

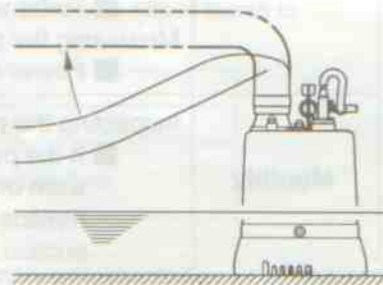

Operating Water Level

- ! CAUTION** Do not operate the pump below Continuous running Water Level (C.W.L.) of 5mm or less, as doing so will damage the pump, causing current leakage and electrical shock.

To restart the pump, make sure that the operating water level is approximately 10mm.



6 MAINTENANCE AND INSPECTION

Regular maintenance and inspection are indispensable in maintaining the pump's performance. If the pump behaves differently from its normal operating condition, refer to the section "8. Troubleshooting" on page 13 of this manual and take appropriate measures at an early stage. We also recommend that you have a spare pump on hand for an emergency.

Prior to Inspection

! WARNING Make sure that the power supply (i.e. circuit breaker) is disconnected, and remove the cable from the power outlet. Failure to do so may cause electrical shock or unintended starting of the pump, which may lead to serious accidents.

(1) Washing the Pump

Remove any debris attached to the pump's outer surface, and wash the pump with tap water. Pay particular attention to the impeller area, and completely remove any debris from the impeller.

(2) Inspecting the Pump Exterior

Verify that the paint is not peeled, that there is no damage, and that the bolts and nuts have not loosened. If the paint has peeled, wash that area, allow the pump to dry, and apply touch-up paint.

NOTE: Touch-up paint must be provided by the user. If the pump must be disassembled due to damage or loose bolts or nuts, contact the dealer where it was purchased, or the Tsurumi sales office in your area.

Daily and Periodic Inspection

Interval	Inspection Item
Weekly	Measuring insulation resistance ■ Insulation resistance reference value = $1M\Omega$ or greater. NOTE: The motor must be inspected if the insulation resistance is considerably lower than that obtained during the last inspection. Measuring the operating current ■ To be within the rated current Measuring the power supply voltage ■ Power supply voltage tolerance = within $\pm 5\%$ of the rated voltage
Monthly	Inspecting the pump ■ If the pump's performance has diminished significantly, the impeller may be worn or the strainer may be clogged with debris. Remove any debris, and replace the impeller if it is worn. It may also be more effective to replace the suction cover.
Semi-yearly	Inspecting and changing oil NOTE: Refer to the section "Oil Inspection and Change Procedures" on page 10 of this manual.
Yearly	Changing the oil and replacing the mechanical seal NOTE: The inspection and replacement of the mechanical seal requires specialized skills. Therefore, to have this operation performed, contact the dealer where this equipment was purchased, or the Tsurumi sales office in your area.
Once every 2 to 5 years	Overhaul ■ The pump must be overhauled even if the pump appears normal during operation. The pump may need to be overhauled earlier if it is used continuously. NOTE: To overhaul the pump, contact the dealer where it was purchased, or the Tsurumi sales office in your area.

Storage

If the pump will not be operated for a long period of time, pull the pump up, wash the pump, allow it to dry, and store it indoors.

NOTE: For reinstallation, be sure to perform a trial operation before putting the pump into operation.

If the pump remains immersed in water, operate the pump on a regular basis (i.e. once a week) to prevent the impeller from seizing due to rust.

Oil Inspection and Changing Procedures

- Inspection interval: Every 1,000 hours or 6 months, whichever comes first
- Changing interval: Every 2,000 hours or 12 months, whichever comes first.
- Designated oil: Turbine oil VG32
- Oil volume: Specified volume 150ml

Inspecting Oil

Remove the oil plug and take out a small amount of oil. The oil can be extracted by tilting the pump so that the oil plug faces downward. If the oil appears milky or intermixed with water, a likely cause is a defective shaft sealing device (i.e. mechanical seal), which requires that the pump be disassembled and repaired.



Changing Oil

Remove the oil plug and drain the oil completely. Pour a specified volume of oil into the oil inlet.

NOTE: The drained oil must be disposed of by waste disposal contractors in compliance with the laws of the respective country in which the pump is being used.

The packing and the O-ring for the oil plug must be replaced with a new part at each oil inspection and oil change.

Maintenance

The parts listed below are dispensable items. Use the indicated replacement period as a rule of thumb to replacing these parts.

Part name	Replacement period
Mechanical seal	Milky oil
Lubrication oil (turbine oil VG32)	Every 2,000 hours or 12 months, whichever comes first
Packing and O-ring	Each disassembly or inspection
Oil seal	If the sealing lip is worn, and at each disassembly or inspection
Shaft sleeve	When worn
V-ring	When worn

Prior to Disassembly and Reassembly

- ! WARNING**
- Before disassembling and reassembling the pump, be sure that the power supply (i.e. circuit breaker) is disconnected, and remove the power plug from the outlet. Do not connect or disconnect the power plug with a wet hand. To prevent serious accidents, do not perform an activation test (to check the rotation of the impeller) during disassembly and reassembly.
 - During repair, never disassemble or repair areas other than those that are specified in the Operation Manual. To disassemble or repair areas other than those that are specified, consult the dealer where this equipment was purchased, or the Tsurumi sales office in your area. Improper repair may lead to current leakage, electrical shock, fire, or water leakage.
- ! CAUTION**
- Be sure to perform a trial operation when starting the pump after reassembly. If the unit was assembled improperly, it may lead to abnormal operation, electrical shock, or water leakage.

This section explains the disassembly and reassembly processes that are involved up to the replacement of the impeller itself. Operations involving the disassembly and reassembly of the sealing portion (i.e. mechanical seal) and of the motor require a specialized facility including vacuum and electrical test equipment. For these operations, contact the dealer where this equipment was purchased, or the Tsurumi sales office in your area.

Disassembly Procedure

NOTE: To enhance serviceability, this unit has been designed to enable the entire pump portion illustrated below to be disassembled using one 12mm box wrench.

NOTE: Stand the pump upside down with its discharge connection facing downward during disassembly and reassembly. Exercise care to prevent the pump from tipping, which may lead to injury.

- (1) Remove three Hex. Bolts (marked ①) with Washers; then, manually remove the Strainer and the Suction Cover.
- (2) Remove the Hex. Nut, Spring Washer, and Plain Washer (marked ②); then, manually remove the Impeller, Pump Casing, Shaft Sleeve, and the V-Ring.

! CAUTION A worn Impeller often has sharp edges. Be careful not to cut yourself on the edges.

Disassembly Diagram

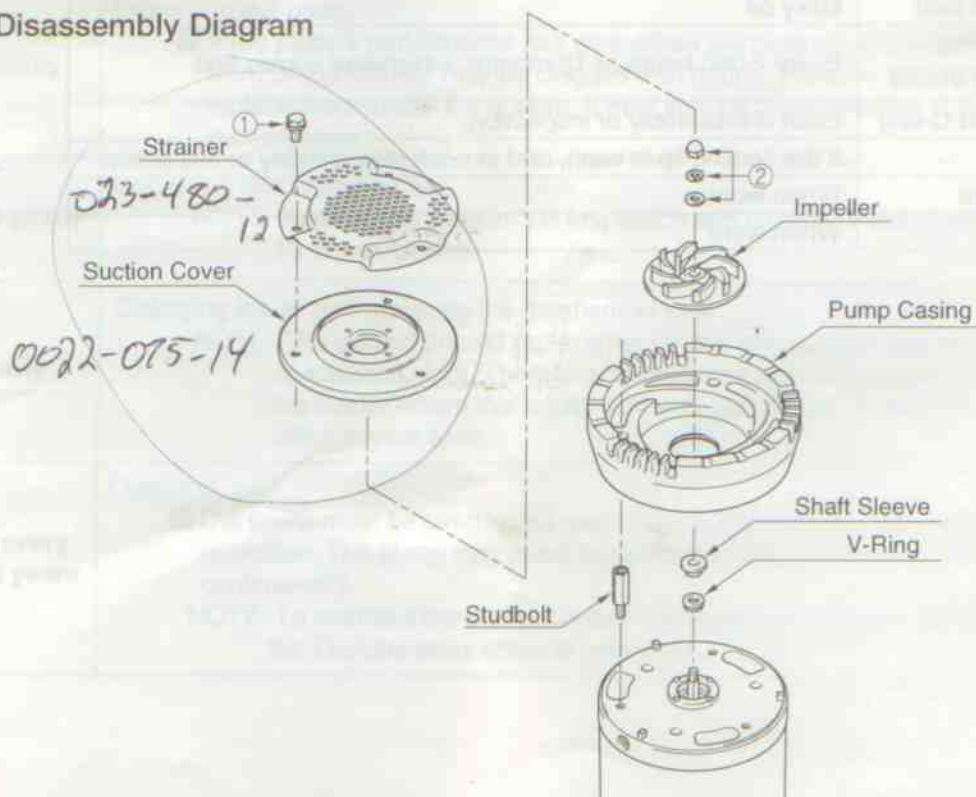

Reassembly Procedure

The reassembly procedure is the reverse sequence of disassembly.

(1) First remove sand or other debris from the Impeller, Pump Casing, and Suction Cover before reassembly.

(2) Install the V-Ring on the outside of the Shaft Sleeve, as shown in Fig. 1. During the installation, make sure not to apply Oil to the area in which the V-Ring contacts the Shaft Sleeve.

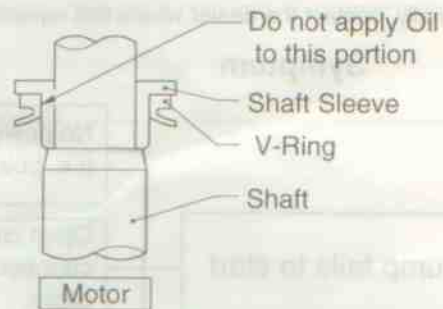

Fig. 1

(3) During the assembly of the Pump Casing, make sure to press it firmly against the contact surface. The flange portion on the inside of the Oil Casing has four tabs, as shown in Fig. 2. Make sure to firmly press the Pump Casing until it engages with those tabs.

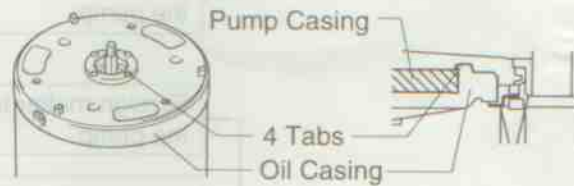

Fig. 2

NOTE:

- The Packing must be replaced with a new part. Also replace any parts that are worn or damaged.
- After installing the Impeller, check that it rotates smoothly.

8 TROUBLESHOOTING

! WARNING To prevent serious accidents, disconnect the power supply before inspecting the pump.

Read this Operation Manual carefully before requesting repair. After re-inspecting the pump, if it does not operate normally, contact the dealer where this equipment was purchased, or the Tsurumi sales office in your area.

Symptom	Cause	Countermeasure
Pump fails to start	No power is supplied (i.e. power outage).	Contact the electric power company or an electrical repair shop.
	Open circuit or poor connection of the cabtyre cable.	Check if there is an open circuit in the cabtyre cable or wiring.
	Foreign matter is wedged in the pump.	Inspect the pump and remove the foreign matter.
Pump starts but stops immediately, causing the circuit breaker to trip.	Foreign matter is wedged in the pump.	Inspect the pump and remove the foreign matter.
	The voltage is low.	Correct the voltage to the rated voltage, or use an extension cable that meets the standard.
	A 50 Hz model is operated at 60 Hz.	Check the nameplate and replace the pump or the impeller.
	The strainer became clogged, and the pump was operated dry for long hours.	Remove foreign matter from the strainer.
	Motor abnormal.	Repair the motor or replace with a new motor.
The pump's head and pumping volume is low.	The pump is picking up too much sediment.	Place a concrete block under the pump to prevent the pump from picking up sediment.
	The impeller is worn.	Replace.
	The hose may be kinked or clogged.	Minimize the number of bends in the hose. (In an area with a large amount of debris, use the pump in a meshed basket.)
The pump generates noise or vibration.	The strainer is clogged or the pump is buried.	Remove debris from the strainer. Place a concrete block under the pump to prevent the pump from picking up sediment.
	The bearing of the motor is damaged.	To replace the bearing, contact the dealer where this equipment was purchased, or the Tsurumi sales office in your area.

The information listed below is needed for repair or for contacting Tsurumi.

Product model	
Manufacturing number	
Purchase date	
Remarks	

LSR2.4S Model

OPERATION & SERVICE MANUAL

TSURUMI PUMP



TSURUMI MANUFACTURING CO., LTD.

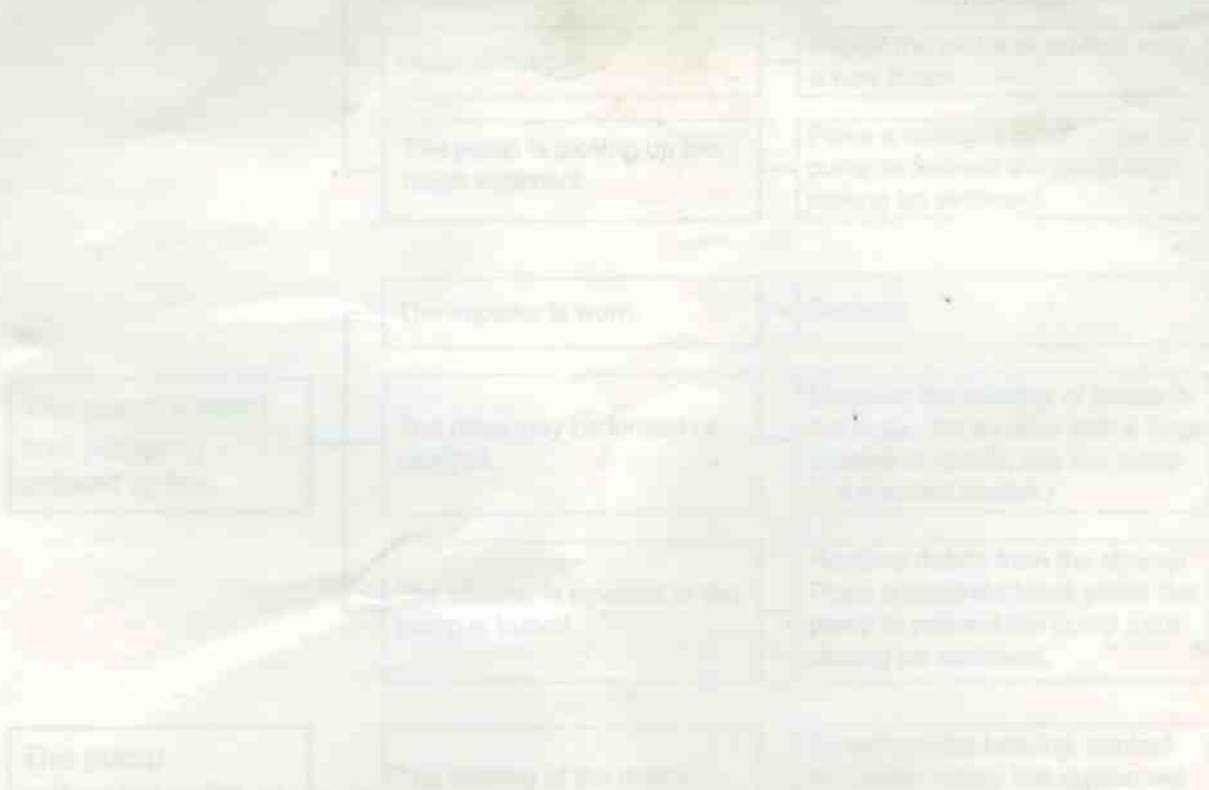
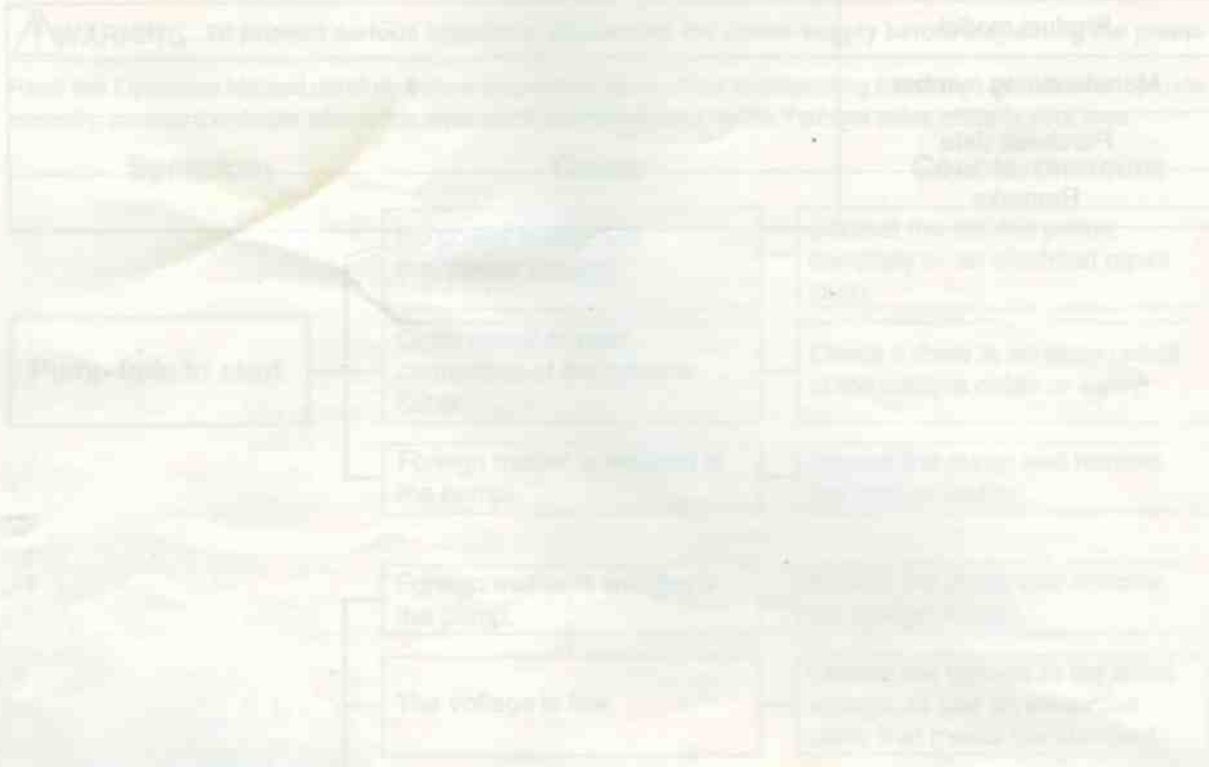

TSURUMI MANUFACTURING CO., LTD.